

DC Axial Fan

CNDC



□ 120 × 38 (□ 4.7" × 1.5")
Max. airflow: 4.4 m³/min
Max. static pressure: 160 Pa
Mass: 250 g

Fan model code

- CNDC12B7
- CNDC12B7P
- CNDC12B7S
- CNDC12D7
- CNDC12D7P
- CNDC12D7V
- CNDC12H7
- CNDC12U7
- CNDC12Z7
- CNDC12Z7P
- CNDC12Z7Q
- CNDC12Z7S
- CNDC24B7
- CNDC24B7P
- CNDC24B7Q
- CNDC24B7S
- CNDC24B7SQ
- CNDC24B7V
- CNDC24B7VS
- CNDC24D7
- CNDC24D7Q
- CNDC24D7S
- CNDC24H7
- CNDC24U7
- CNDC24Z7
- CNDC24Z7P
- CNDC24Z7Q
- CNDC24Z7S
- CNDC24Z7V
- CNDC48B7
- CNDC48B7P
- CNDC48B7S
- CNDC48Z7
- CNDC48Z7P
- CNDC48Z7S
- CNDC48Z7V

Standard specification

Max. Airflow m ³ /min	Max. Static Pressure CFM Pa	Noise inH ₂ O dB	Speed min ⁻¹	Input W	Voltage Spec. V		Current mA		Model Code		Operating Temp. Range °C		
					Rating	Operating Range	Rating	Starting	Open Flange	With Spacer			
4.4	155	160	0.64	52	3800	12	8.4-13.8	930	2100	CNDC12U7	-20 ~ +70		
						10.8	24	19.2-27.6	450	2000		CNDC24U7	
4.0	141	140	0.56	51	3550	12	8.4-13.8	760	2080	CNDC12H7			
						9.4	24	19.2-27.6	390	1970		CNDC24H7	
3.5	124	105	0.42	49	3200	12	7.2-13.8	710	2350	CNDC12Z7			
						9.0	24	12-27.6	370	1200		CNDC24Z7	CNDC24Z7V
						10.0	48	24-55.2	210	530		CNDC48Z7	CNDC48Z7V
2.8	99	70	0.28	40	2650	12	7.2-13.8	380	1330	CNDC12B7			
						4.8	24	12-27.6	200	640		CNDC24B7	CNDC24B7V
						6	48	24-55.2	120	340		CNDC48B7	
2.1	74	44	0.18	32	1950	12	8.4-13.8	200		CNDC12D7		CNDC12D7V	
						2.6	24	14.4-27.6	110			CNDC24D7	

- Figures in the table are average measured values. Please request the product delivery specification when preparing a purchase specification.
- The characteristics are the values at rated voltage (12 V, 24 V or 48 V), and normal temperature and humidity.
- The life expectancy of CNDC-Z speed products at rated voltage and in continuous operation is 30,000 hours at 60°C. (40,000 hours for other products)

General specification

With Spacer	Venturi: ABS and PBT synthetic resins Propeller: ABS and PBT synthetic resins Bearing: Both side shielded ball bearing
Motor	Brushless DC motor, Protection type: Current shut off by detecting lock state, automatically reset
Common Elec. Spec.	See pages G-11, G-12, G-13.
Standard Carton	40 to a carton of (450 x 380 x 300) mm, mass 12 kg

● Venturi shape

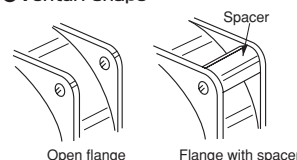

Use the reinforced product with spacer when the venturi is mounted with screws. (The spacer is indicated in the model code by the letter 'V'.)

Standard airflow and static pressure characteristics (At rated voltage)

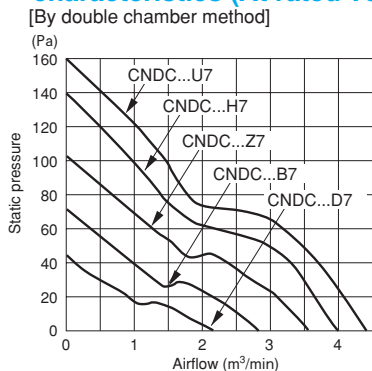

Wiring connection diagram

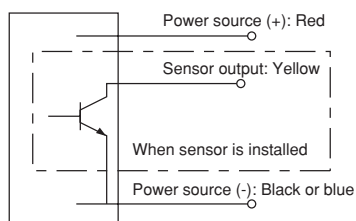

DC axial fan with sensor

Rated Vol.	Model Code		
12 V	CNDC12D7P	CNDC12B7S CNDC12B7P	CNDC12Z7S CNDC12Z7Q
	CNDC24D7S CNDC24D7Q	CNDC24B7S CNDC24B7VS CNDC24B7P CNDC24B7Q CNDC24B7SQ	CNDC24Z7S CNDC24Z7P CNDC24Z7Q
24 V			
48 V		CNDC48B7S CNDC48B7P	CNDC48Z7S CNDC48Z7P

- NIDEC SERVO can meet many of your requirements for customization, such as special connectors, other sensors not listed above, variable speed specifications, and other modifications. Please contact NIDEC SERVO during your product planning and development stage.
- The listed products are registered in the following overseas standards files, UL/cUL: E48889 (Except H, U speed models), CSA: LR49399 (H, U speed model only), TUV: R9451586
- 3D data is also available at our web2-CAD site (www.cadenas.co.jp).

External dimensions in mm (inches)

- Lead wire type Lead wire spec. AWG24 UL1007 or UL3266
Color (+) Red
(-) Black (CNDC□D7: Blue)

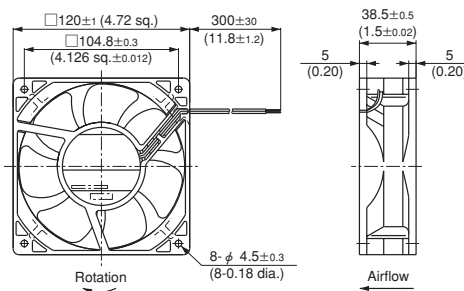

Mounting hole dimensions in mm (inches) [Recommendation]

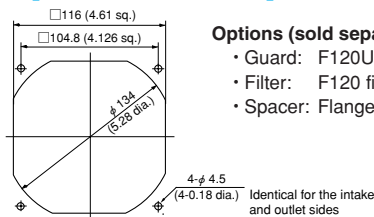

Options (sold separately)

- Guard: F120UL guard
- Filter: F120 filter
- Spacer: Flange spacer CNDC

F60P Guard (Mass 4 g)

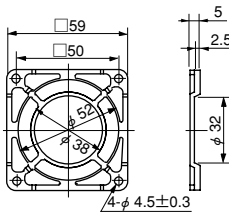

Material: Polycarbonate (black)
UL94V-2

F60UL Guard (Mass 12 g)

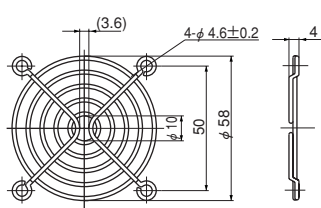

Material: Mild steel wire 1.6 dia.
Surface treatment:
Nickel chromium plating

F80UL Guard (Mass 14 g)

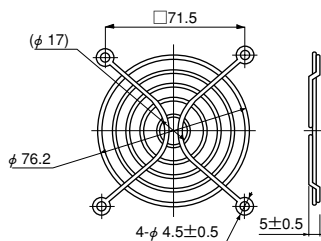

Material: Mild steel wire 1.6 dia.
Surface treatment:
Nickel chromium plating

F92UL Guard (Mass 16 g)

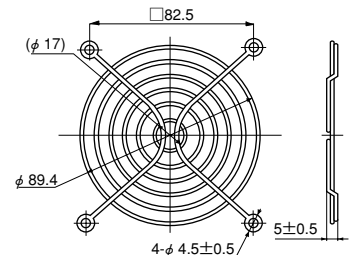

Material: Mild steel wire 1.6 dia.
Surface treatment:
Nickel chromium plating

F120UL Guard (Mass 29 g)

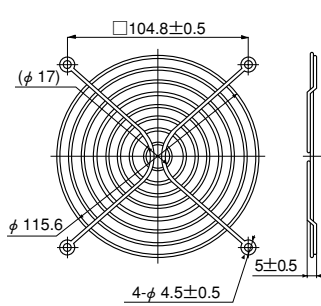

Material: Mild steel wire 1.6 dia.
Surface treatment:
Nickel chromium plating

F127UL Guard

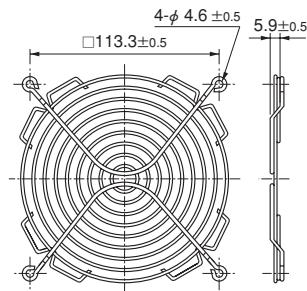

Material: Mild steel wire 1.6 dia.
Surface treatment:
Nickel chromium plating

GUARD 172

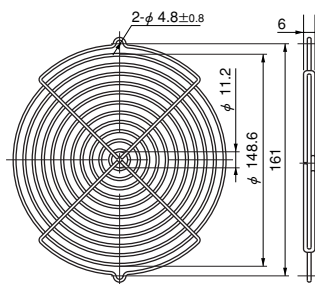

Material: Mild steel wire 2 dia.
Surface treatment:
Nickel chromium plating

F180UL Guard

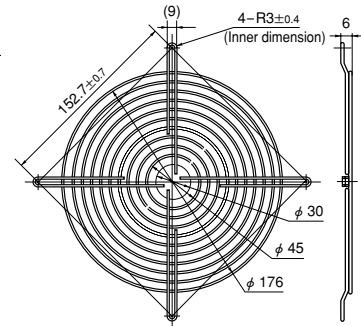

Material: Mild steel wire 1.6 dia.
Surface treatment:
Nickel chromium plating

F200UL Guard (Mass 82 g)

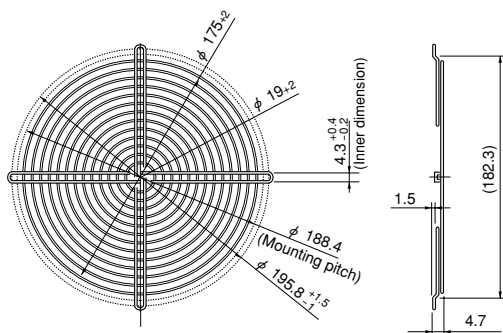

Material: Mild steel wire 1.6 dia.
Surface treatment:
Nickel chromium plating

SCN Guard (Mass 55 g)

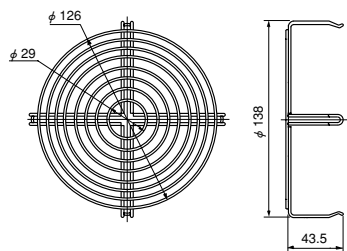

Material: Mild steel wire 1.6 dia.
Surface treatment:
Nickel chromium plating

• Guard special for intake side of
SCN (metal venturi) fans.

List of mating fan series

Guard	F60P	F60UL	F80UL	F92UL	F120UL	F127UL	GUARD 172	F180UL	F200UL	SCN
SCN					○*1					○*2
AC Axial Fans			○	○						
VE			○							
WE				○						
KA				○						
CU					○					
CN					○					
MA							○			
PA							○			
DC Axial Fans	○	○	○	○	○	○				
TUDC	○	○								
PUDC			○							
KUDC				○						
DO925C				○						
KLDC				○						
CUDC					○					
D1225C					○					
DC Axial Fans										
CNDC					○					
D1238T					○					
D1238B					○					
D1338B						○				
D1338S						○				
D1751M							○			
D1751S							○			
G0638D		○								
G0838C			○							
G0938B				○						
G1238B					○					
G1751M								○		

*1: Can be installed only on outlet side. *2: Can be installed only on intake side.
All guards conform to the UL standard when combined with NIDEC SERVO fans.
The installation of a filter, guard and other accessories will constitute a ventilating load, reducing the airflow. Select a suitable guard, taking into consideration the increase in air resistance. (See Figs. 12 and 13 on page G-7.)

Filter

3-piece set

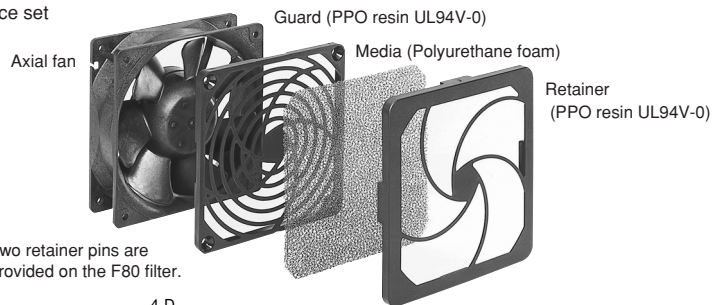

Note: Two retainer pins are provided on the F80 filter.

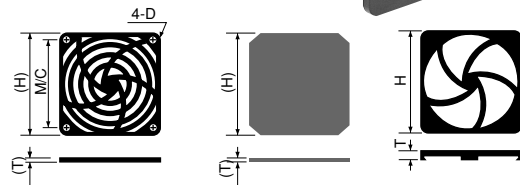

List of mating fan series

Filter	F80	F92	F120
PUDC	○		
KUDC		○	
D0925C		○	
KLDC		○	
CUDC			○
D1225C			○
CNDC			○
D1238T			○
D1238B			○
G0838C	○		
G0938B		○	
G1238B			○

Filter	F80	F92	F120
VE	○		
WE		○	
KA		○	
CU			○
CN			○

Component (Model Code)	H	T	M/C	D
F80 Filter	83.6	10	71.5	φ 3.8
F92 Filter	96.5	10	82.5	φ 3.8
F120 Filter	123.7	10.7	104.8	φ 4.6

Flange spacer

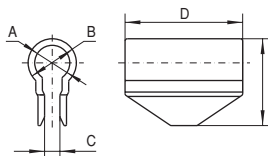

Component (Model Code)	A mm	B mm	C mm	D mm	E mm	Mating Model Code
Flange Spacer PUDC (※)	5	8	2	17	14.5	KUDC,PUDC
Flange Spacer CUDC (※)	8	11	3.5	15	19.8	CUDC
Flange Spacer CNDC	8	11	3.5	28	19.8	CNDC

※Ribbed venturis (PUDC-R, CUDC-R) are available for PUDC and CUDC.

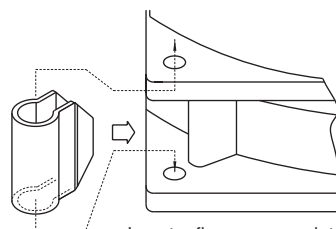

Insert a flange spacer into the ribs of a venturi.

(Installing a flange spacer)

Inlet ring

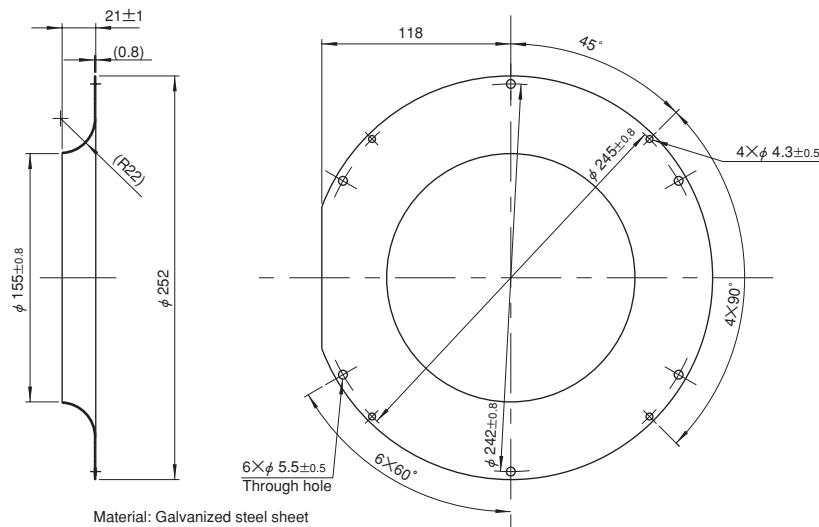

Component (Model Code)	Mating Model Code
E2271 Inlet ring	E2271Z

DC axial fans & blowers with sensors

The DC fans and blowers of NIDEC SERVO have a function to send an alarm signal when the fan motor revolutions slow down. Several systems are used to cut off the system power supply by this alarm signal, with three types of sensors available. Select the right type of sensor in accordance with the purpose of use. The lead wire for the sensor is yellow. The output type is an open collector output for all three types.

■ Sensor type

1. Lock detection type (Product code: S)

The output signal indicates an [L] state (transistor is ON) while the propeller is rotating, changing to an [H] state (transistor is OFF) less than five seconds after the propeller stops rotating. The propeller automatically restarts operation within five seconds when the lock is unlocked. ([H] → [L] 5 s). If the pull-up voltage is live, the [H] state (transistor is OFF) will engage in less than five seconds, even when the power is turned off.

- Specification: $V_{CE} = 28\text{ V max}$ (55.2 V max for 48 V products)
- Output waveform
- $I_C = 5\text{ mA max}$
- ($V_{CE(SAT)} = 0.4\text{ V max}$)

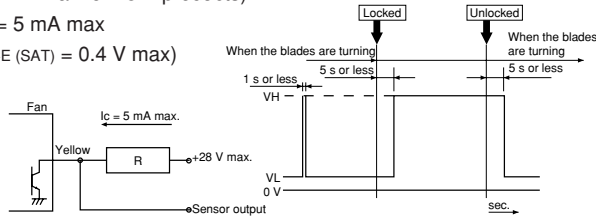

※When the power is turned on, the state sometimes becomes high [H] for several hundred ms.

2. Pulse output type (Product code: P)

A rectangular wave of two pulses will be output for each turn of the propeller while the propeller is rotating, outputting two types of signal depending on the propeller position when the propeller is locked. (See the note below ※)

- Specification: $V_{CE} = 28\text{ V max}$ (55.2 V max for 48 V products)
- Output waveform
- $I_C = 5\text{ mA max}$
- ($V_{CE(SAT)} = 0.4\text{ V max}$)

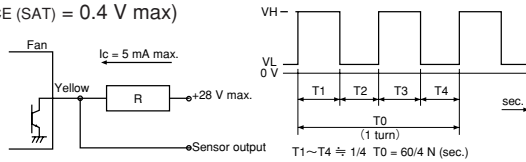

※Output signal waveform when the fan is stopped: The following two types of waveform are output, depending on the blade position when the propeller is stopped:
Pulse outputs of High - constant or restart timing (0.05 Hz to 2 Hz).

3. Speed detection type (Product code: Q)

The output signal indicates the [H] state when the propeller revolutions are slower than the preset speed, changing to the [L] state when the propeller revolutions exceed the reset speed.

[Products with a reversed output waveform are also available, suitable for a wired OR connection when several fans are installed. Contact NIDEC SERVO for further information. {Former code: SQ, new code (15 - digit code products): R}]

- Specification: $V_{CE} = 28\text{ V max}$ (55.2 V max for 48 V products)
- $I_C = 5\text{ mA max}$
- ($V_{CE(SAT)} = 0.4\text{ V max at } 5\text{ mA}$)

● Output waveform

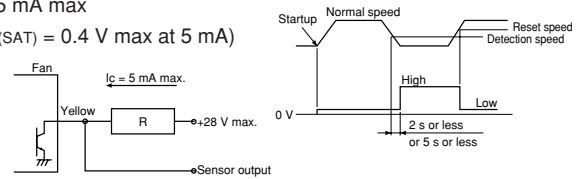

Note: The output waveform for type SQ (R) will be reversed. The speed setting for the alarm output is about half the rated speed. For more detailed information, please request a product delivery specification from NIDEC SERVO.