

DME34

MODEL CODE	VOLTAGE	OUTPUT	CURRENT
SA	12V	1.3W	0.2A
SB	24V	1.3W	0.1A
BA	12V	4.5W	0.65A
BB	24V	4.5W	0.31A
KB	24V	7W	0.41A

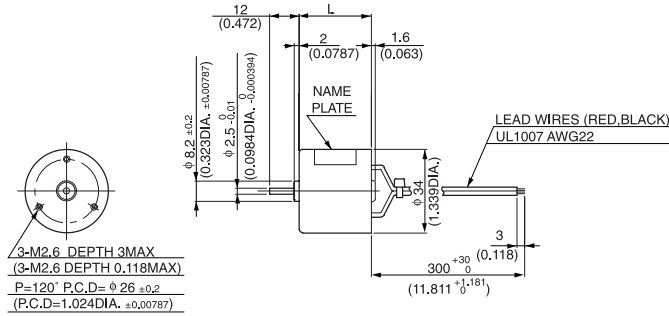

● DIMENSIONS Unit mm(inch)



Model	L	Weight	
		g	lb
DME34SA	29.5	100	0.22
DME34SB	29.5	100	0.22
DME34BA	35.0	110	0.24
DME34BB	35.0	110	0.24
DME34KB	45	140	0.31

● CONNECTION

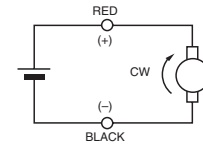

● CURRENT, SPEED-TORQUE CURVE

DME34SA, DME34SB

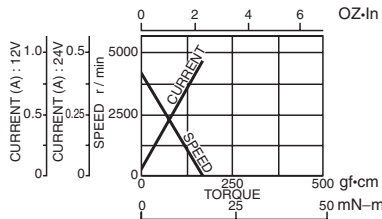

DME34BA, DME34BB

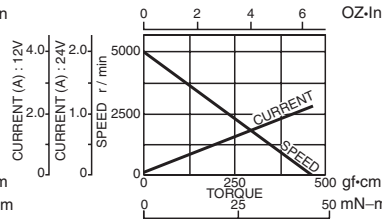

DME34KB

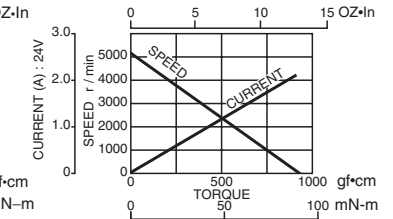

● STANDARD SPECIFICATIONS

Model	Rated					No load		Stall torque		
	Output W	Voltage V	Torque		Current A	Speed r/min	Current A	Speed r/min	mN·m	oz·in
			mN·m	oz·in						
DME34SA	1.3	12	3.9	0.56	0.2	3300	0.04	4300	17	2.36
DME34SB	1.3	24	3.9	0.56	0.1	3300	0.02	4300	17	2.36
DME34BA	4.5	12	11.8	1.67	0.65	3700	0.07	5000	45	6.39
DME34BB	4.5	24	11.8	1.67	0.31	3700	0.04	5000	45	6.39
DME34KB	7	24	14.7	2.08	0.41	4300	0.06	5100	92	13.03

● REVOLUTION SENSOR MAGNET TYPE

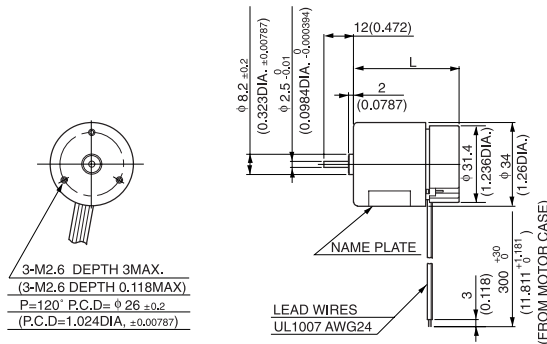

Model	L	Weight	
		g	lb
DME34SMA	43.1	110	0.24
DME34SMB	43.1	110	0.24
DME34BMA	48.6	120	0.26
DME34BMB	48.6	120	0.26
DME34KMB	58.6	150	0.33

DME34

MODEL CODE	VOLTAGE	OUTPUT	CURRENT
SA	12V	1.3W	0.2A
SB	24V	1.3W	0.1A
BA	12V	4.5W	0.65A
BB	24V	4.5W	0.31A
KB	24V	7W	0.41A

● REVOLUTION SENSOR OPTICAL TYPE

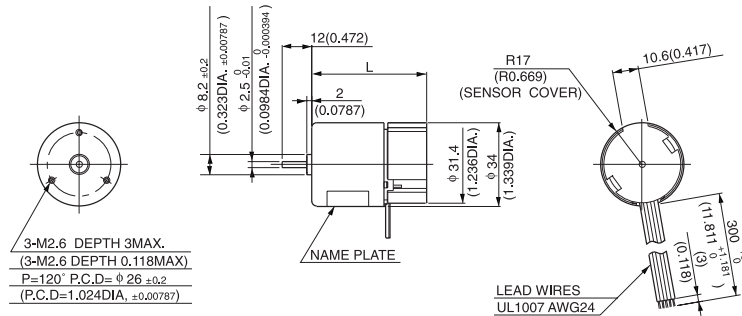

Model	L	Weight	
		g	lb
DME34SEA	47.1	120	0.26
DME34SEB			
DME34BEA	52.6	130	0.29
DME34BEB			
DME34KEB	62.6	160	0.35

● CONNECTION OF REVOLUTION SENSOR

DME34SMA, DME34SMB, DME34BMA, DME34BMB
 DME34SEA, DME34SEB, DME34BEA, DME34BEB

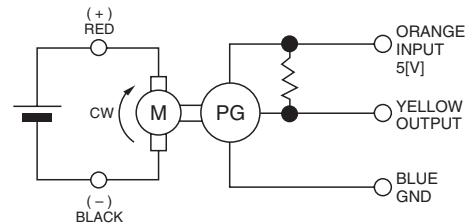

● SPECIFICATION OF REVOLUTION SENSOR ARE SHOWN ON PAGE 8.

WITH GEARBOX
36G

Gear heads for
 intermittent drive



36G

● DIMENSIONS Unit mm(inch)

DME34S36G

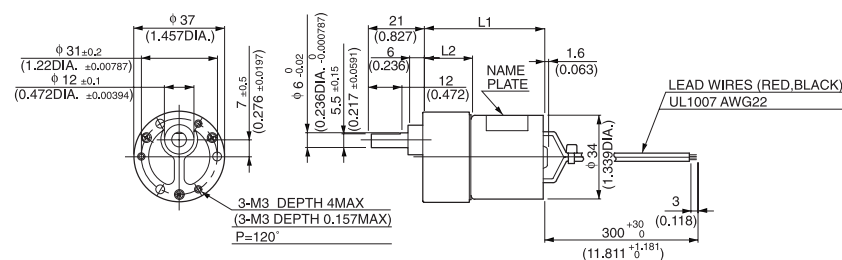

GEAR RATIO	L1		L2		WEIGHT	
	(mm)	(inch)	(mm)	(inch)	g	lb
10	49.3	1.941	19.8	0.78	200	0.44
18~30	51.8	2.039	22.3	0.878		
50~100	54.3	2.138	24.8	0.976		
120~300	56.8	2.236	27.3	1.075	220	0.49
400~600	59.3	2.335	29.8	1.173		

●with 43G TYPE GEARBOX

Model	Gear ratio		10	*18	*20	*30	50	60	75	100	*120	*150
	Rated speed	r/min	330	183	165	110	66	55	44	33	27.5	22
DME34S43G □ ☆	Rated torque	N·m	0.031	0.052	0.06	0.09	0.12	0.14	0.18	0.25	0.27	0.34
		oz·in	4.44	7.22	8.33	12.50	18.05	20.83	26.39	36.11	38.88	48.61
DME34B43G □ ☆	Rated speed	r/min	370	205	185	123	74	65	54.9	43.4	36.5	30
		Rated torque	N·m	0.095	0.14	0.16	0.25	0.38	0.39	0.39	0.39	0.39
		oz·in	13.47	20.83	23.61	36.11	54.16	55.55	55.55	55.55	55.55	55.55

Model	Gear ratio		*180	*200	*250	*300	400	500	600
	Rated speed	r/min	18.6	17.2	14.5	12.4	9.5	7.8	6.6
DME34S43G □ ☆	Rated torque	N·m	0.39	0.39	0.39	0.39	0.39	0.39	0.39
		oz·in	55.55	55.55	55.55	55.55	55.55	55.55	55.55
DME34B43G □ ☆	Rated speed	r/min	25.5	23.1	18.8	15.8	12	9.6	8.1
		Rated torque	N·m	0.39	0.39	0.39	0.39	0.39	0.39
		oz·in	55.55	55.55	55.55	55.55	55.55	55.55	55.55

WITH GEARBOX
50G



50G

●DIMENSIONS Unit mm(inch)
DME34B50G

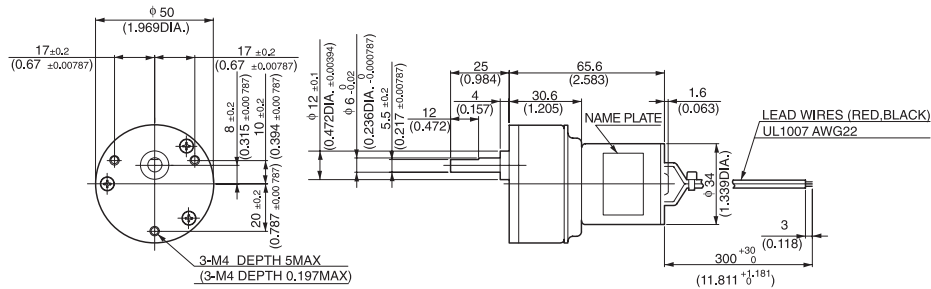

(WEIGHT 310g 0.68lb)

●with 50G TYPE GEARBOX

Model	Gear ratio		9	18	*27	*36	*54	*72	96	144	192	256
	Rated speed	r/min	411	205	137	102	68.5	51.4	38.5	26.7	21.5	17
DME34B50G □ ☆	Rated torque	N·m	0.085	0.17	0.23	0.3	0.46	0.62	0.74	0.98	0.98	0.98
		oz·in	12.08	23.61	31.94	43.05	65.27	87.49	104.15	138.87	138.87	138.87

WITH GEARBOX

L
Gear heads for
intermittent drive



L

●DIMENSIONS Unit mm(inch)

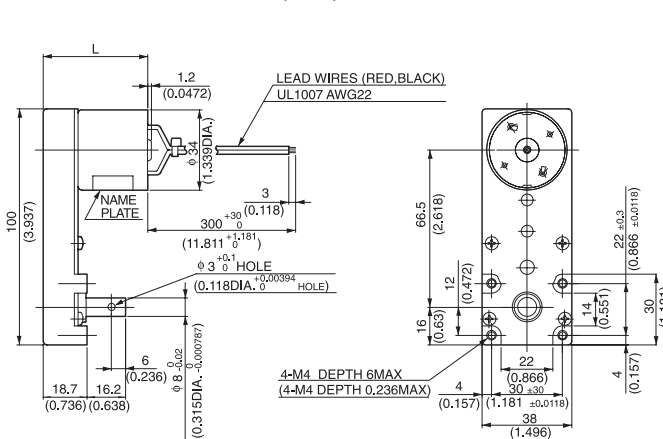

Model	L	Weight	
		g	lb
DME34SL	44.3	270	0.6
DME34BL	49.8	280	0.62
DME34KL	59.8	310	0.68

NOTE 1: Enter the required reduction ratio in the □.
2: *Rotation of gearbox shaft is in reverse of rotation of motor.
3: Enter the required voltage A or B in the ☆.

DME34

MODEL CODE	VOLTAGE	OUTPUT	CURRENT
SA	12V	1.3W	0.2A
SB	24V	1.3W	0.1A
BA	12V	4.5W	0.65A
BB	24V	4.5W	0.31A
KB	24V	7W	0.41A

WITH GEARBOX

L

Gear heads for intermittent drive

●with L TYPE GEARBOX

Model	Gear ratio		30	50	120	150	200	255
	Rated speed	r/min	110	66	27	22	16	13
DME34SL□☆	Rated torque	N·m	0.07	0.11	0.28	0.34	0.46	0.59
		oz·in	9.72	15.28	38.88	48.61	65.27	83.32
DME34BL□☆	Rated speed	r/min	123	74	30.8	25.1	20.4	16.8
		Rated torque	N·m	0.21	0.34	0.83	0.98	0.98
	oz·in		29.16	48.61	118.04	138.87	138.87	138.87
DME34KL□B	Rated speed	r/min	143	86.0	36.2	30.0	23.2	18.6
		Rated torque	N·m	0.26	0.43	0.98	0.98	0.98
	oz·in		36.81	60.88	138.87	138.87	138.87	138.87

NOTE 1: Enter the required reduction ratio in the □.
 2: *Rotation of gearbox shaft is in reverse of rotation of motor.
 3: Enter the required voltage A or B in the ☆.

WITH GEARBOX

5C

Gear heads for intermittent drive



5C

●DIMENSIONS Unit mm(inch)

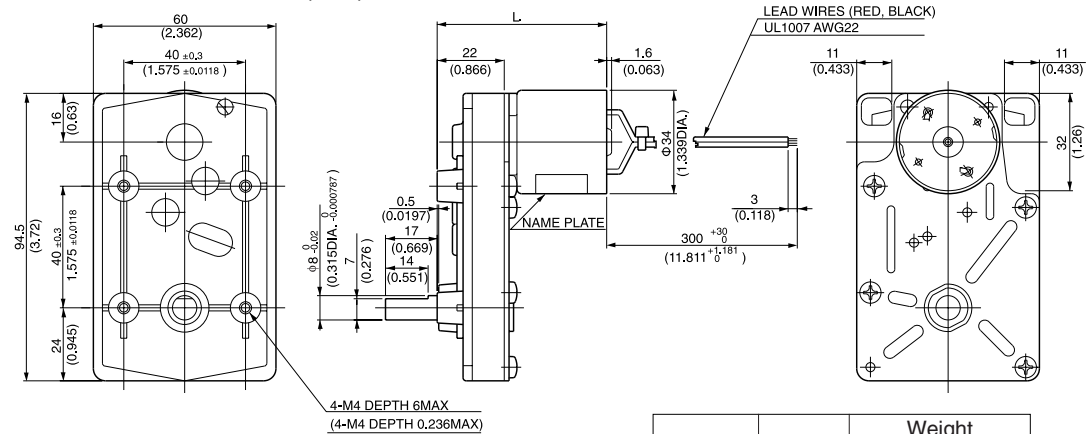

Model	L	Weight	
		g	lb
DME34S5C	55.7	310	0.68
DME34B5C	61.2	320	0.71
DME34K5C	71.2	350	0.77

●with 5C TYPE GEARBOX

Model	Gear ratio		*20	*30	*40	*50	*60	*80	*100	*150	200	250
	Rated speed	r/min	165	110	82.5	66	55	41.2	33	22	16.5	13.2
DME34S5C□☆	Rated torque	N·m	0.057	0.085	0.11	0.14	0.17	0.23	0.28	0.42	0.51	0.64
		oz·in	8.05	12.08	15.28	19.44	23.61	31.94	40.27	59.71	72.21	90.27
DME34B5C□☆	Rated speed	r/min	185	123	92.5	74	61.6	46.2	37	26.7	20.8	17.3
		Rated torque	N·m	0.17	0.25	0.34	0.42	0.51	0.69	0.85	0.98	0.98
	oz·in		23.61	36.11	48.61	59.71	72.21	97.21	120.82	138.87	138.87	138.87
DME34K5C□B	Rated speed	r/min	215	143	107	86.0	71.6	53.7	43.7	30.7	23.4	19.1
		Rated torque	N·m	0.21	0.32	0.43	0.53	0.64	0.85	0.98	0.98	0.98
	oz·in		29.73	45.31	60.88	75.04	90.62	120.35	138.87	138.87	138.87	138.87

Model	Gear ratio		300	400	500
	Rated speed	r/min	11	8.3	7
DME34S5C□☆	Rated torque	N·m	0.77	0.98	0.98
		oz·in	108.32	138.87	138.87
DME34B5C□☆	Rated speed	r/min	14.8	11.4	9.3
		Rated torque	N·m	0.98	0.98
	oz·in		138.87	138.87	138.87
DME34K5C□B	Rated speed	r/min	16.1	12.2	9.87
		Rated torque	N·m	0.98	0.98
	oz·in		138.87	138.87	138.87

NOTE 1: Enter the required reduction ratio in the □.
 2: *Rotation of gearbox shaft is in reverse of rotation of motor.
 3: Enter the required voltage A or B in the ☆.