

Stepping motors make it easy to control position and speed, and they are used in many applications. However, stepping motors driven with a conventional open-loop control are sometimes unable to provide satisfactory results in response to the strong demand for improved equipment performance and reliability. Therefore, there are an increasing number of applications which use a closed loop control system that employs a sensor. This catalog is intended to introduce you to stepping motor products for driving at high speed and with high accuracy, without the use of any sensors. They are built using proprietary technology that we developed.

OUTLINE

Stepping servos are the type of products to which we applied our original technology for driving stepping motors at high speed and with high accuracy. The products covered in this introduction include both stepping motors and drivers that can be operated at high speed, thanks to a new control system which monitors the rotor position and controls the excitation timing. Although our motors are standard 2-phase stepping motors, a 0.72° step angle is achieved using this driver (which is the same as in 5-phase stepping motors). The basic resolution of 0.72° can be further divided into 80 parts (0.009°) using a micro-step function. This driver improves high-speed operation. Also, an out-of-step condition can now be detected in stepping motors and drivers, which is a first. (This is only possible at motor shaft speeds of 500 rpm or higher.)

FEATURES

Stepping motors that can be operated at high speed:

Thanks to a new control system, in which the rotor position is monitored and the excitation timing is controlled, motors can be run at 2000 rpm or more without using an external damper. This new control system is effective in saving space by eliminating an external damper and in reducing the tact time of a high-speed drive.

Thin drivers with a micro-step function:

These are 24V DC input drivers. A micro-step drive electrically subdivides the basic step angle, making it possible to have a basic step angle ranging from 0.72° to 0.009° without using a gear head. The resolution can be easily set using a rotary switch attached to a driver. The driver size is 5.31 (L) x 2.89 (W) x 1 (H), and the driver design is very thin. These drivers are most suitable in applications involving multiple shafts.

Vibration suppression:

Since a spark-advance-control-system drive circuit controls the phase of the current relative to the polar position, vibration control is possible in principle. This is supplemented by our own vibration suppression function which uses a microcomputer. With this function, vibration at high speeds is effectively suppressed, leaving only a very small amount of vibration.

Variety of output signals:

Previously, detecting an out-of-step condition in a stepping motor was not possible using only stepping motors and drivers. Now the impossible has become possible using polar position information. (At 500 rpm or more) Detecting this signal allows more accurate control. In addition to this signal, an alarm signal and an index signal are output.



Price list

Driver type	Price	Motor type	Price of the main unit	5% tax	Total price
FWD2B1P15-11	List price of the main unit:	KH42HM2-951	3,800	190	3,990
FWD2B1P15-21		KH42JM2-951	3,950	198	4,148
FWD2B1P15-31		KH42KM2-951	4,100	205	4,305
FWD2B2P15-41	21,800	KH60JM2-951	7,300	365	7,665
FWD2B2P15-51	5% tax:	KH60KM2-951	8,000	400	8,400
FWD2B2P15-11	1,090	KH56JM2-951	4,100	205	4,305
FWD2B2P15-21	Total price:	KH56KM2-951	4,100	205	4,305
FWD2B2P15-31		KH56QM2-951	5,700	285	5,985

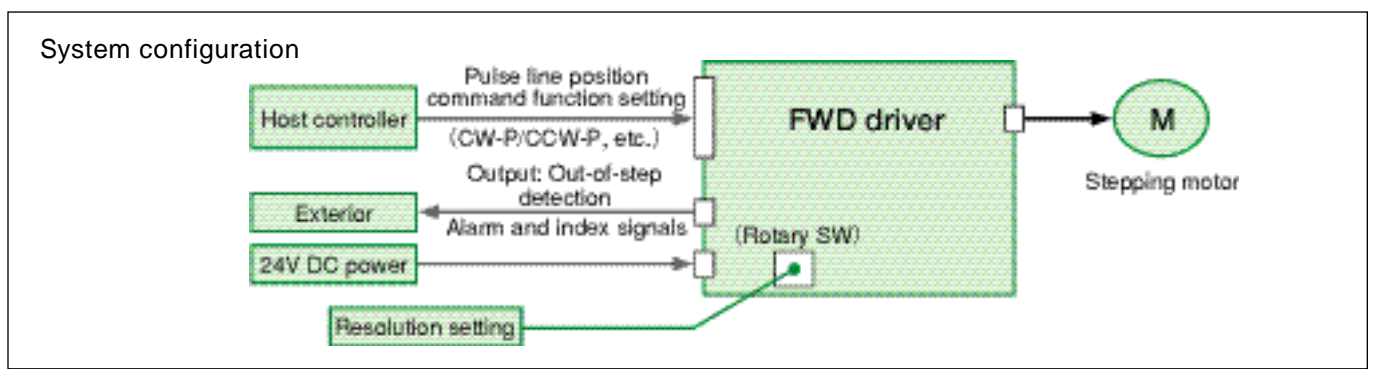
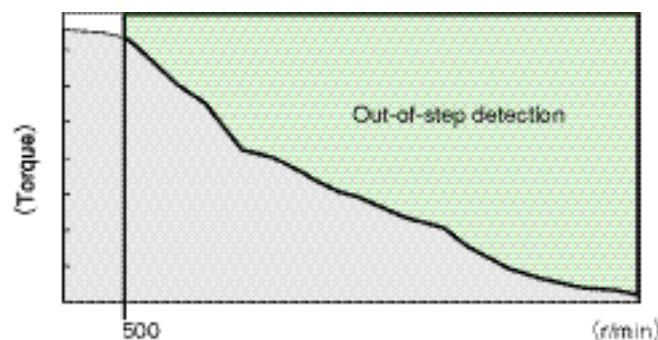
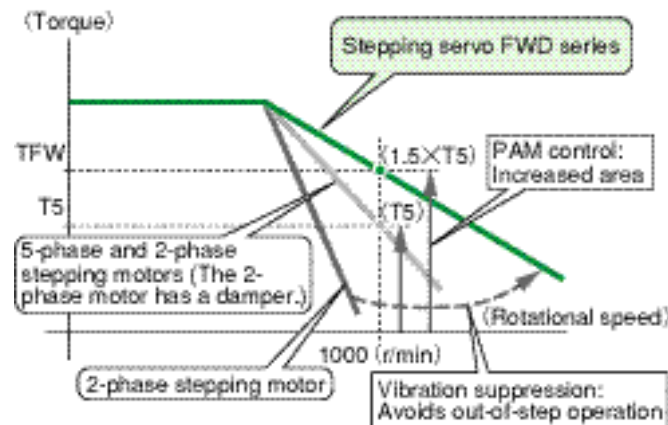

General specifications

	Driver section	Motor section
Insulation class	—	Equivalent to E class
Insulation resistance	—	500VDC 100MΩ min
Dielectric strength	—	500VAC 50Hz 1min
Working environment	Ambient temperature	0~+50°C
	Ambient humidity	0~+50°C 15~85%
Storage environment	Ambient temperature	0~+50°C
	Ambient humidity	35~85% 10~85%

Installation location

Installation conditions	Precautions for installation
When installed in a control panel	Design the control panel, including the size, driver placement, and cooling method, so that the temperature at the edges of the FWD driver is always 50°C or less.
When installed near a heating element	Minimize any heat radiated from a heating element and limit temperature increases using convection, so that the temperature at the edges of the FWD driver is always 50°C or less.
When installed near a source of vibration	Install a vibration damping device on the driver mounting surface, so that no vibration is transmitted to the FWD driver.
When installed in a location where corrosive gas is present	Devise a way to prevent corrosive gas from coming into contact with these devices. Although it will not cause immediate harm to these devices, it may cause failure in equipment related to the contactor.
Other	Do not install the system in places exposed to high temperatures, high humidity, lots of dust or metal powder.

How to identify the types

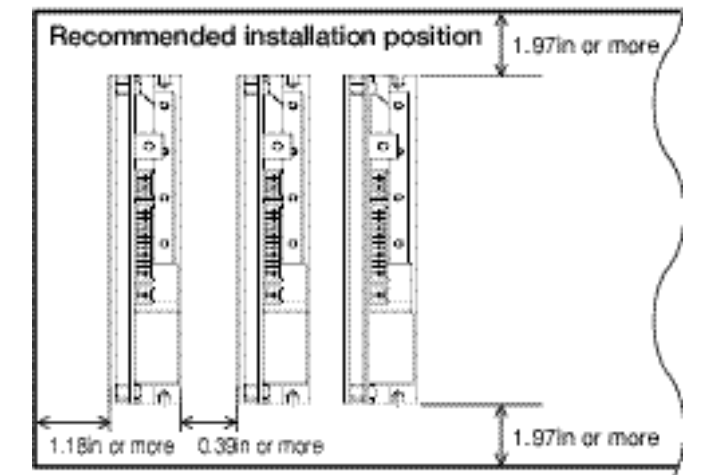
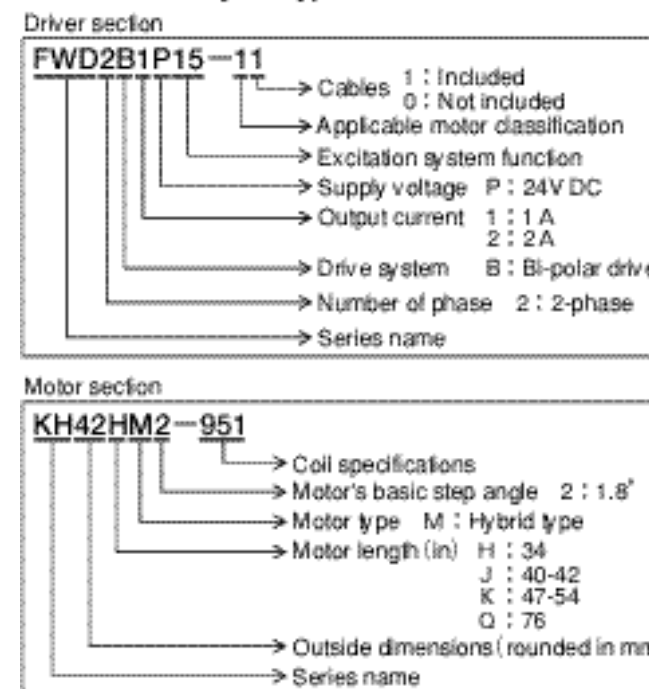

Specifications

Driver type	Applicable motors	Number of phase	Basic resolution	Excitation system	Rated current (A/phase)	Max. static torque (mN·m (oz·in))	Rotor inertia (oz·in·S ²)	Power specifications (DC)	Driver mass (lb)	Motor mass (lb)
FWD2B1P15-11	KH42HM2-951	2	0.72°	*Micro step Basic resolution/n (Step)	0.8	169(23.9)	0.54X10 ⁻³	24V, 2.0A	0.51	0.44
FWD2B1P15-21	KH42JM2-951				0.8	314(44.5)	0.79X10 ⁻³	24V, 2.0A		0.57
FWD2B1P15-31	KH42KM2-951				1.2	427(60.5)	1.2X10 ⁻³	24V, 2.5A		0.79
FWD2B2P15-41	KH60JM2-951				2.0	918(130)	3.89X10 ⁻³	24V, 4.0A		1.32
FWD2B2P15-51	KH60KM2-951				2.0	1360(192)	5.66X10 ⁻³	24V, 4.0A		1.70
FWD2B2P15-11	KH56JM2-951				2.0	491(69.5)	1.63X10 ⁻³	24V, 3.0A		0.88
FWD2B2P15-21	KH56KM2-951				2.0	915(130)	2.66X10 ⁻³	24V, 3.5A		1.43
FWD2B2P15-31	KH56QM2-951				2.0	1510(214)	3.81X10 ⁻³	24V, 4.0A		2.03

*n=1,2,4,8,10,20,40,80

■ Connection method

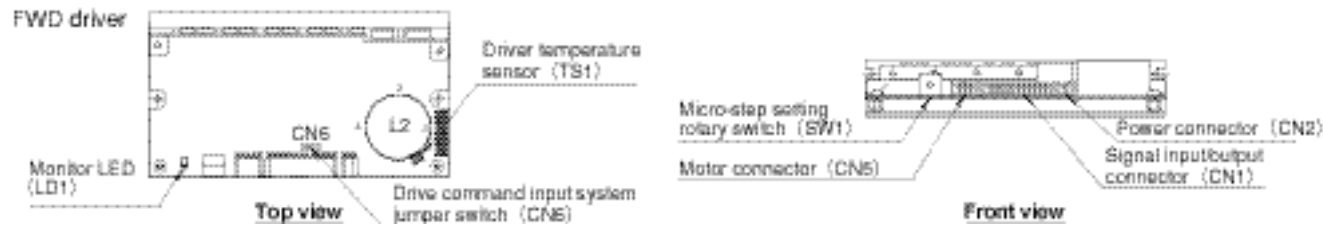

■ Common specification for drivers

Supply voltage	24V DC±10%
Input signals	TTL input (internally pulled up)
CW pulse signal/pulse signal	CW direction operation command pulse signal (jumper switch (CN6) selecting between pins 2 and 3: Operation command pulse signal)
CCW pulse signal/rotation direction signal	CCW direction operation command pulse signal (jumper switch (CN6) selecting between pins 2 and 3: Rotation direction signal)
Hold-off signal	H.OFF signal "H": Excitation OFF, "L": Excitation ON
Automatic current save signal	SAVE signal "H": 50%, "L": 75%
Output signals	Open collector output (+5 - 24V, 10 mA or less)
Index signal	The index signal is synchronized with the input pulse. When the pulses for 7.2 degrees of rotation are input (at any step angle setting), the index signal outputs "L" once. (Please note that the index signal is a feedback output from the driver independent of the actual rotation of the motor.) Set the drive pulse frequency to 1 kHz or less.
Alarm output	When any of the abnormalities shown in the separate table occur, an "H" signal will be output on the ALM terminal. When everything is normal: "L"
Out-of-step detection signal	When the motor gets out-of-step at 500 rpm or more, an "H" signal is output to the PSW terminal. When it is normal: "L". When the driver is restored to normal operation, the signal is cleared.
Micro-step angle selection	Selected in eight steps using the rotary switch.
Cooling system	Natural cooling

■ Functional description

Drive command input system	This driver can select two types of the drive command input system. The input system type is selected using a jumper switch (CN6). Changes in this setting only become valid after resetting the power.
Hold-off function	Motor excitation is set to ON or OFF using the H.OFF terminal. The setting can be changed during operation.
Automatic current save function	This function allows the current applied to the motor to be 50% or 75% of the rated value 0.5 seconds after the motor stops. The setting value of this function is set using the SAVE terminal. The setting can be changed during operation.
Motor current value setting	The motor current value is set using the C0 and C1 terminals. The setting can be changed during operation.
Micro-step angle setting	This setting is made with a rotary switch (SW1). It is necessary to reset the power to make the change effective.
Index signal	Only a single "H" signal is output to the INDEX terminal for a motor rotation angle of 7.2° then this signal is used for positioning the origin, set the drive pulse frequency to 1 kHz or less.
Alarm signal	When any of the following abnormalities occur, an "H" signal will be output on the ALM terminal and the motor will enter a no-current state. To clear the alarm, you must reset the power.
Out-of-step detection signal	When the motor does not follow the number of rotation commands normally while being driven, it is regarded as out-of-step and an "H" signal is output on the SYNC_OUT terminal. This function is only valid when the motor revolution speed is 500 rpm or more. When the driver is restored to normal operation, the signal will be cleared. The motor does not enter the no-current state.

■ Function setting

Terminal No.	Function details	Logic
	Drive command input system jumper position (CN6)	CW/CCW pulse signal input: between pins 1 and 2 Pulse/rotation direction signal input: between pins 2 and 3
1	CW rotation	Pulse
2	CCW rotation	"H" or open
1	CCW rotation	"H" or open
2	CW rotation	Pulse
1	CCW rotation	"H" or open
2	CW rotation	"L"
3	Hold-off function	Excitation OFF: "H" or open Excitation ON: "L"
4	Automatic current save function	50%: "H" or open 75%: "L"
8	Motor current %	100%: "L" 75%: "H" 50%: "H"
9	Combination setting	"L" "L" "L"
6	Alarm output	Normal operation: "L" Abnormality: "H"
7	Out-of-step detection function	Normal operation: "L" Out-of-step: "H"

■ List of alarm signal outputs

Abnormalities	Conditions causing the alarm
Overcurrent	When the peak current value of the motor exceeds the value shown in the following table
Overvoltage	When the inverter voltage is 46V or more
Overspeed	When a drive pulse signal of 4000 rpm or higher is input
Dangerous overheating	When the temperature sensor detects a temperature of 70°C or more
CPU abnormal	When the CPU runs away

■ Overcurrent value (peak value)

FWD2B1P15-11	FWD2B2P15-11
FWD2B1P15-21	FWD2B2P15-21
FWD2B2P15-31	FWD2B2P15-31
	FWD2B2P15-41
	FWD2B2P15-51
2.5 A/phase or more	5.0 A/phase or more

■ Description of the monitor LEDs

Normal operation and abnormalities are indicated by the lighting and/or flashing of the two color LEDs.

	Function	Green LED	Red LED
Lit	Normal operation	○	—
	Hold-off	—	○
Flashing	Overcurrent	Once	Twice
	Overvoltage	Once	Three times
	Overspeed	Once	Four times
	Dangerous overheating	Once	Five times
	Motor out-of-step	Twice	Once
	CPU abnormal	Three times	Once

■ Rotary switch setting

Rotary switch position	0-B	1-9	2-A	3-B	4-C	5-D	6-E	7-F
Step angle [°/step]	0.72	0.36	0.18	0.09	0.072	0.036	0.018	0.009

The rotary switch position when shipped from the factory is "0".

■ Jumper switch setting

Jumper position	Drive command input system	CW terminal	CCW terminal
Between 1 and 2	CW/CCW pulse signal input	CW pulse signal	CCW pulse signal
Between 2 and 3	Pulse/rotation direction signal input system	Pulse signal	Rotation direction signal

CN6
1 2 3

* Note: The jumper switch setting only becomes effective after resetting the power.

■ Input signal circuit

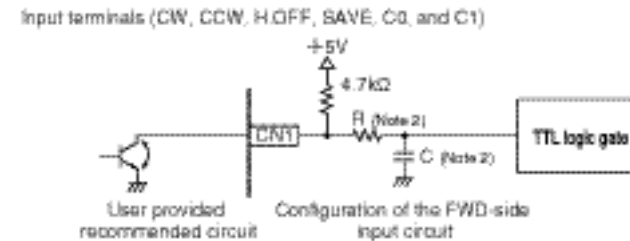

* Note 2: The R and C values are different for each terminal, as shown in the table on the right.

Input circuit constant		
Terminal name	R	C
CW, CCW	1kΩ	100pF
H, OFF, SAVE	4.7kΩ	2200pF
CO, C1	560Ω	2200pF

■ Output signal circuit

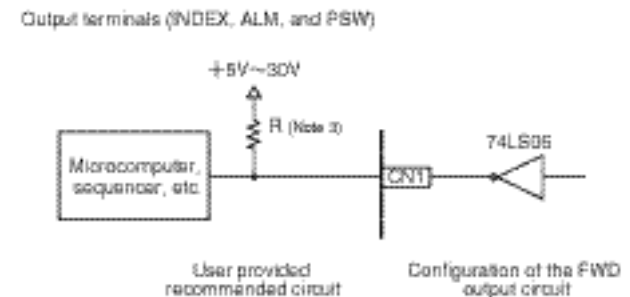

* Note 3: Set the value of pull-up resistor R so that the current draw of the 74LS05 is 10 mA or less per terminal when L is output.

■ List of connector terminal names

Connector name	Terminal No.	Color	Terminal name	Function
CN1	1	Brown	CW	CW pulse signal or pulse signal input
	2	Red	CCW	CCW pulse signal or rotation direction signal
	3	Orange	H.OFF	Motor excitation ON/OFF signal input
	4	Yellow	SAVE	Automatic current save change signal input
	5	Green	INDEX	Index signal output
	6	Blue	ALM	Alarm signal output
	7	Purple	SYNC_OUT	Out-of-step detection signal output
	8	Gray	C0	Motor current value setting signal input
	9	White	C1	
	10	Black		
	11	Brown	GND	Signal ground
	12	Red		
CN2	1	Red	VM	Connect to +24V DC.
	2	Black	GND	Power supply ground
CN5	1	Red	A	A-phase output
	2	Blue	A	A-phase output
	3	Yellow	B	B-phase output
	4	White	B	B-phase output

■ Connector specification

	Driver side	User provided		Manufacturer
	Type	Applicable housing	Applicable contact	
CN1	53426-1210	51103-1200	50752-8000 (link)	MOLEX
CN2	53426-0210	51103-0200	50752-8100 (random)	
CN5	53426-0410	51103-0400		

■ Input/output signal standard

Item	Symbol	Standard value	
		MIN	MAX
H level input voltage	V _{Ih} (V)	4.2	—
L level input voltage	V _{Il} (V)	—	0.6
H pulse width	T _{wh} (μs)	1.0	—
L pulse width	T _{wl} (μs)	1.0	—

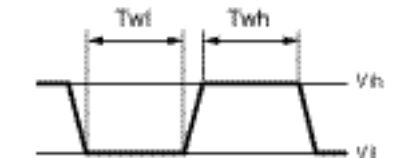

■ Power specification

Driver supply voltage (VM): 21.6V - 26.4V

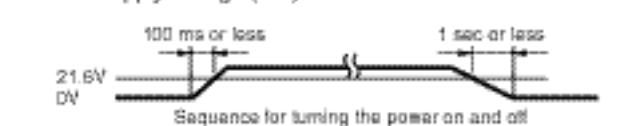

Precautions when turning the power on and off
 • Only apply signals after the power has stabilized.
 • Allow at least 0.5 seconds between power resets.